



CSE 423 VTR.



2-radiant rings.

- Vitroceramic hob.
- 1 x 3.5 kW square plate, 300 x 300 mm.
- 1 x 1.2 kW ring, Ø 140 mm.
- Total power: 4.7 kW.
- Electric supply: 230 V single phase.

CSE 423 VTR

W 400 - D 650 - H 300

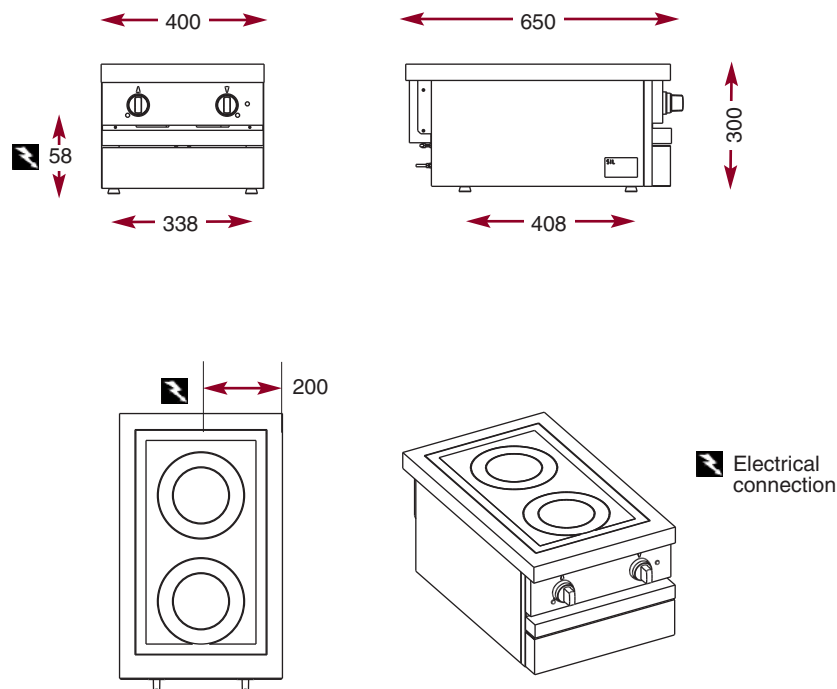

The modules have the same features and performances as the cupboard units. They are designed to be fixed onto tubular steel supports but can also be installed on stainless steel or tiled worktops.

Tubular stainless steel supports for the modules. (All the supports are made of Ø 60mm stainless steel tubes and are fitted with a stainless steel shelf and height adjustable feet).

Ref.	Dimensions
SSK 400	W 400 - D 540 - H 600
SSK 600	W 600 - D 540 - H 600
SSK 700	W 700 - D 540 - H 600
SSK 800	W 800 - D 540 - H 600
SSK 1000	W 1000 - D 540 - H 600
SSK 1100	W 1100 - D 540 - H 600
SSK 1200	W 1200 - D 540 - H 600
SSK 1300	W 1300 - D 540 - H 600
SSK 1400	W 1400 - D 540 - H 600
SSK 1500	W 1500 - D 540 - H 600
SSK 1600	W 1600 - D 540 - H 600

